

KEYSTONE KNIFEGATE VALVES

FIGURE 952

Lugged style, uni-directional knife gate valves



FEATURES

- Compact design.
- Self-aligning gland box.
- Both S.G. Iron and 316 S/S valves available (depending on valve size).
- One piece integral cast body, chest and lugs.
- Integral cast in gate wedges minimise flow obstructions.
- High quality gate finish for optimum sealing.
- High flow rates with low pressure drops.
- Integral RTFE gate scraper.
- Gate guides to support gate.
- A range of seat options available.
- Complies with MSS SP-81 face-to-face dimensions.
- All valves are pressure tested to MSS SP-81.
- Maintenance friendly.

GENERAL APPLICATIONS

The Keystone K-Nife is designed for a wide range of applications such as:

- Pulp and paper
- Mining
- Effluent handling plants
- Chemical plants
- Food and beverage
- Fly ash handling plants
- Bulk conveying
- Corrosive environments

TECHNICAL DATA

Size range:	DN 50 - 600
Temperature rating:	150°C RTFE seated 150°C FKM seated 230°C 316 S/S seated 230°C S.G. Iron seated
Pressure rating:	1000 kPa (10 bar) at cold working pressure (non-shock)

KEYSTONE KNIFEGATE VALVES

FIGURE 952

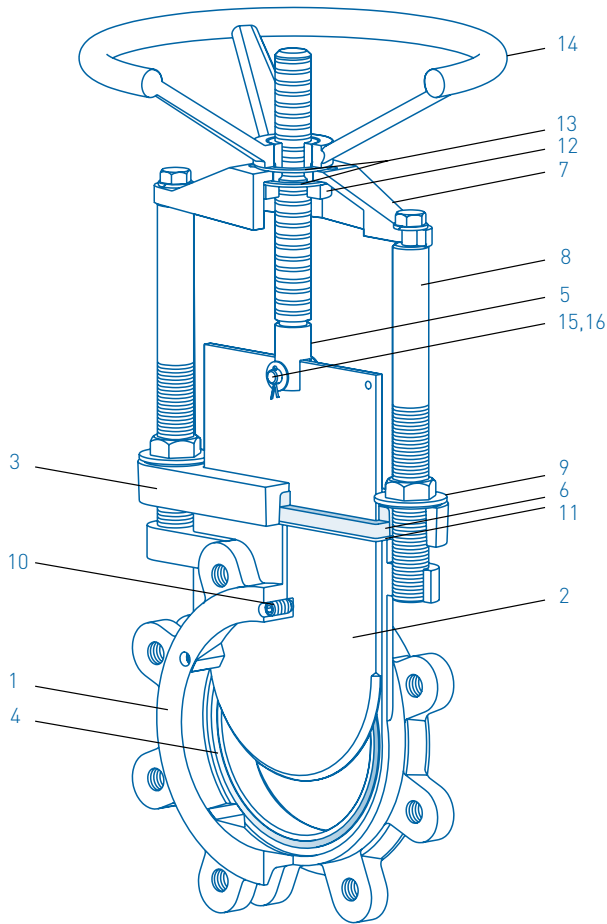

NOTE: DN 50 - 200 valve illustrated

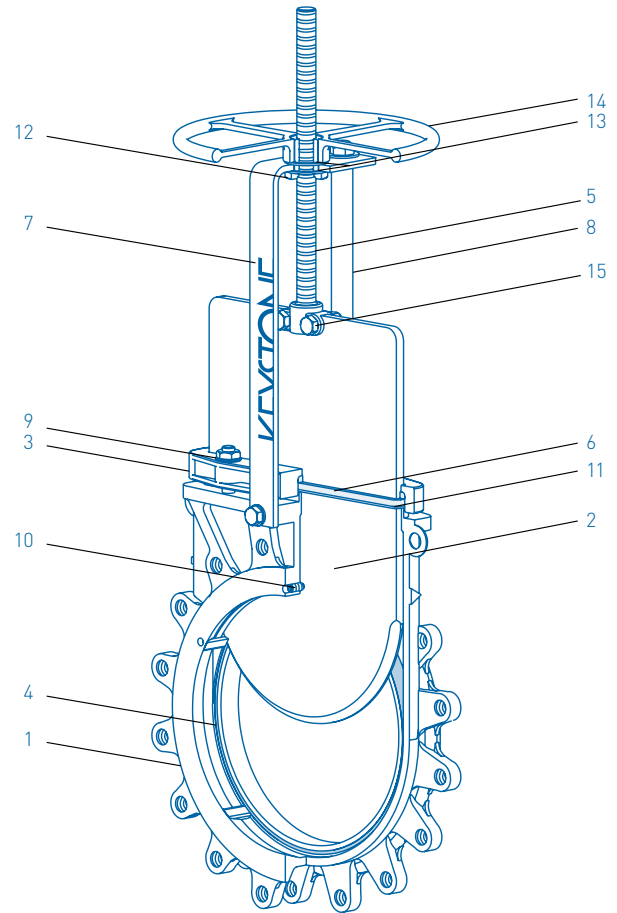

NOTE: DN 250 - 600 valve illustrated

PARTS LIST

No.	Description	Material
1	Body	316 S/S or S.G. Iron
2	Gate#	316 S/S, SAF 2205 or SAF2507
3	Gland box	304 S/S or S.G. Iron
4	Seat	RTFE, Metal or FKM
5	Spindle	304 S/S
6	Gland packing	K-LON•
7	Bridge (50 - 200 mm) Upstand (250 - 600 mm)	304 S/S Painted mild steel
8	Pillar	304 S/S or painted mild steel
9	Glandbox washer	Nylon
10	Gate guide	S/S RTFE tipped
11	Gate scraper	RTFE
12	Handwheel nut	Leaded gunmetal
13	Thrust washer	Nylon
14	Handwheel	S/S (non-rising) or S.G Iron (rising)
15	Clevis pin	304 S/S
16	Split pin	304 S/S
17	All fasteners	304 S/S

OPTIONS

- F738 Pneumatic actuators
- Electric actuators
- Bevel gear operators
- Chainwheels
- F459 Quick acting lever (50 - 200 mm)
- F791 Solenoid valves
- Limit switches
- F793 Positioners
- F493 Pneumatic failsafe
- Deflection cones
 - Chrome iron
 - Polyurethane (50 - 300 mm)
- Safety guards and shrouds

NOTE

- # Gate is PTFE coated when used with FKM seat.
- Other packing materials available on request.

KEYSTONE KNIFEGATE VALVES

FIGURE 952

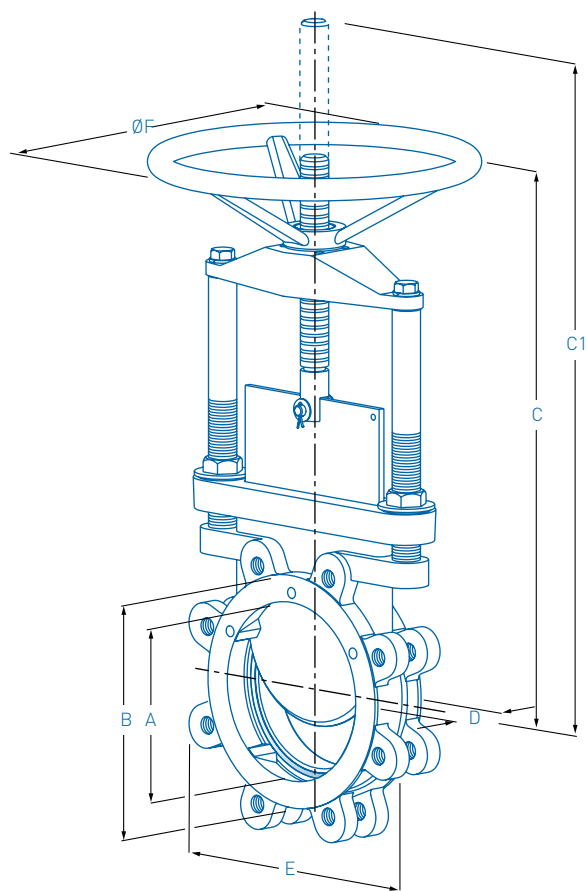

NOTE: DN 50 - 200 valve illustrated.
Number of lugs is dependent upon flange drilling.

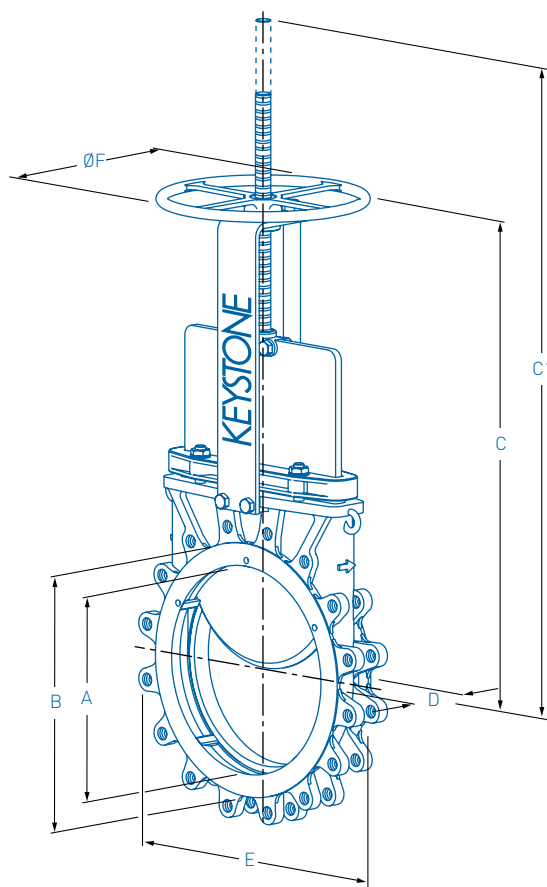

Note: DN 250 - 600 valve illustrated.
Number of lugs is dependent upon flange drilling.

DIMENSIONS (mm)

Valve size DN	Bore (downstream)		Rising spindle		Non-rising	D	E	ØF	Nom. mass manual (kg)	K _v at full open*
	A	B	(closed) C	(open) C1						
50	50	92	264	295	N/A	49	159	200	7	223
65	65	108	284	316	N/A	49	177	200	8	368
80	80	127	324	391	N/A	52	192	200	10	557
100	100	157	358	425	N/A	52	222	200	12	909
125	125	186	450	519	N/A	58	256	300	18	1416
150	150	212	487	579	N/A	58	285	300	22	2112
200	200	270	602	746	N/A	71	325	300	34	4065
250	250	326	726	908	693	71	406	400	47	6850
300	300	380	825	1057	793	76	474	400	74	9863
350	330	452	881	1144	848	76	520	400	93	11858
400	378	480	968	1281	935	89	584	400	121	15590
450	425	540	1095	1450	1084	89	628	600	170	20165
500	475	585	1192	1598	1181	114	696	600	212	25117
600	571	692	1400	1881	1369	114	822	600	312	36896

NOTES

Dimension D = the face to face dimension

Dimension E = the maximum valve or upstand clearance dimension for installation

*K_v = the flow rate of water in m³/hr that will pass through a valve with a differential pressure of 1 bar (100 kPa) at 20°C

C_v = 1.155 K_v

Dimensions are nominal.

Larger sizes are available upon request.

N/A = Not Available

KEYSTONE KNIFEGATE VALVES

FIGURE 952

STANDARD SEAT DETAIL



PRESSURE/TEMPERATURE GRAPH

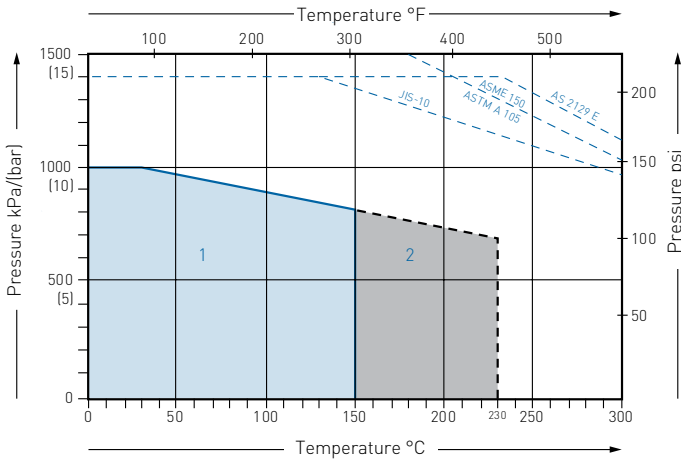

PRESSURE/TEMPERATURE RATINGS

RTFE seated

1000 kPa/(10 bar) at 20°C
770 kPa/(7.7 bar) at 150°C

Metal seated

1000 kPa/(10 bar) at 20°C
700 kPa/(7 bar) at 230°C

FKM seated

1000 kPa/(10 bar) at 20°C
770 kPa/(7 bar) at 150°C

1. RTFE seated valve trim code numbers are 176, 177.
FKM seated valve trim code number is 180.
2. Metal - S.G. Iron seated valve trim code numbers are 170, 172.
Metal - 316 S/S seated valve trim code numbers are 170, 171.
Metal - 304 S/S seated valve trim code number is 185.

SELECTION GUIDE

Example:	250	F952	170	AS 2129 E
Valve size	DN 50-600			
Figure number	F952			
F952	Lugged style rising spindle uni-directional valve.			
Trim	See table			
End connections (to suit)	AS 2129 Table C, D, E metric threads			
ASME B16.5	Class 125 & 150 UNC threads			
BS 4504	PN 10 and 16			
JIS B2210	Table 5, 10			
DIN 2501	Table 10, 16			
ASME B16.5	Class 125 and 150 metric threads (for N.Z.)			

NOTE

- * Gates are 316 S/S, coated with PTFE.
 - Available in sizes 350 - 600 mm only.
- Non-rising spindle design available upon request

NOTE

To minimise risk to personnel, Pentair recommend the use of purpose built guards and shrouds. Refer to the Pentair data sheet or consult factory for details.

Trim code	Body	Gate	Seat	Gland box	Bridge	Spindle	Packing
172●	S.G. Iron	316 S/S	S.G. Iron	S.G. Iron	S.G. Iron	304 S/S	K-LON
182●	S.G. Iron	316 S/S	RTFE	S.G. Iron	S.G. Iron	304 S/S	K-LON
170	316 S/S	316 S/S	316 S/S	304 S/S	304 S/S	304 S/S	K-LON
171	316 S/S	316 S/S	316 S/S	S.G. Iron	S.G. Iron	304 S/S	K-LON
176	316 S/S	316 S/S	RTFE	304 S/S	304 S/S	304 S/S	K-LON
177	316 S/S	316 S/S	RTFE	S.G. Iron	S.G. Iron	304 S/S	K-LON
180	316 S/S	316 S/S / PTFE*	FKM	304 S/S	304 S/S	304 S/S	K-LON



PENTAIR VALVES & CONTROLS

www.pentair.com/valves

ООО “ЭВИ Инжиниринг”
02093, г. Киев, ул. Бориспольская, 26з, оф. 111
тел. (044) 36-18-450
e-mail: info@ewi-engineering.com.ua
Website: ewi-engineering.com.ua

All Pentair trademarks and logos are owned by Pentair Inc. All other brand or product names are trademarks or registered marks of their respective owners. Because we are continuously improving our products and services, Pentair reserves the right to change product designs and specifications without notice. Pentair is an equal opportunity employer. © 2012 Pentair Inc. All rights reserved.