

# Hy-Lok 112 Series

## Ball Valves

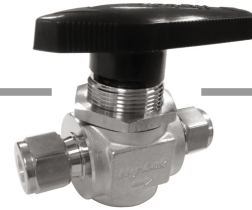

Catalog No. H - 112BV  
Oct. 2013

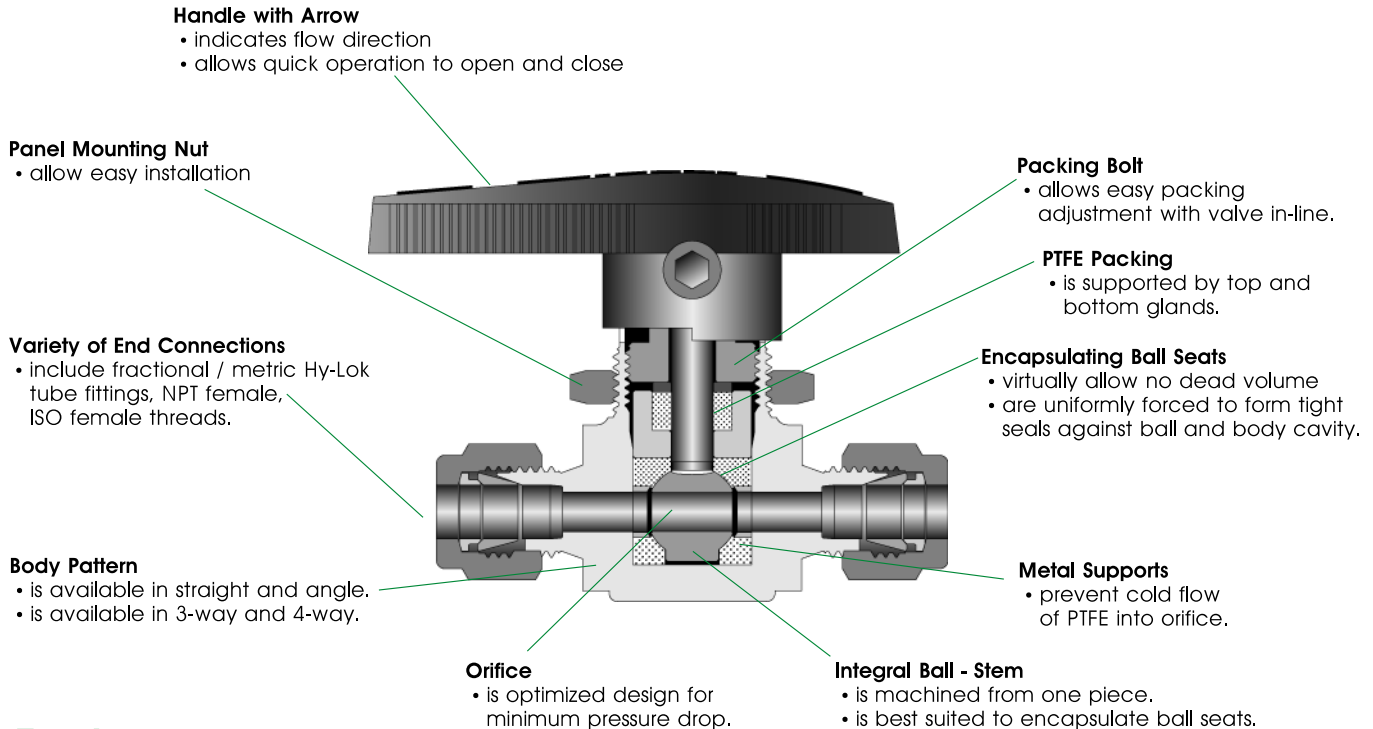

## Features

- **Pressure rating** up to 3000psig (206bar) at 70°F(21°C)
- **Temperature rating** from 50°F to 150°F (10°C to 65°C) with PTFE seat and packing
- **Vent to atmosphere available**
- **Both straight and angle, 3 - way and 4 - way patterns** available
- **Body materials** available in 316 stainless steel, brass, and alloy 400.
- **100% factory tested**

## Technical Data

### Materials of Construction

#### ■ 2 - WAY & 3 - WAY

Description	Grade / ASTM Specification		
	Valve Body Materials		
	SS316	Brass	Alloy 400
Handle	Black Nylon		
Mounting Nut	Stainless Steel	Brass	Stainless Steel
Packing Bolt	TP316 / A479	Brass	TP316 / A479
Packing*	PTFE		
Packing Gland	316 Stainless Steel		
Encapsulating Ball Seats*	PTFE		
Supports*	Stainless Steel		
Ball Stem*	TP316 / A479	N04400 / B164	
Body	TP316 / A479 or A182	Brass / B16	N04400 / B164

Note : "\*" marked are wetted parts. Lubricant is silicone based.

### Pressure Rating @ 50°F to 150°F(10°C to 65°C)

for the valve with standard seat and packing

Valve Designator	Straight 2 - way	Angle 2 - way	Switching 3 - way
B 1 V	2500 psig (172 bar)	2500 psig (172 bar)	2500 psig (172 bar)
B 2 V	3000 psig (206 bar)	2500 psig (172 bar)	2500 psig (172 bar)
B 3 V	2500 psig (172 bar)	1500 psig (103 Bar)	1500 psig (103 bar)
B 4 V	2500 psig (172 bar)	1500 psig (103 bar)	1500 psig (103 bar)



**HY-LOK CORPORATION**

© 2000, 2002, 2013 HY-LOK CORPORATION All rights reserved

## 2 - way (Shut - Off Valve)

### Straight Pattern

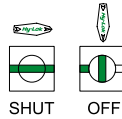
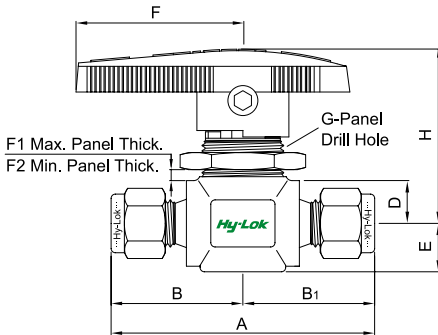

### Angle Pattern

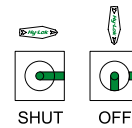
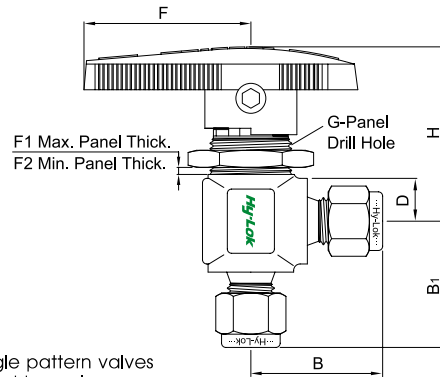

For the dimension B & B1 of angle pattern valves see the dimension of 3-way switching valves

### Table of Dimensions

Basic Part No.	Orifice		CV	End Connection		Dimensions (mm)									
	mm	inch		Inlet & Outlet	A	B	B1	D	E	F	F1	F2	G	H	W
B1VH - 1T	1.3	0,052	0.1	1/16 Hy-Lok	42.6	21.3	21.3	9.5	8.8	28.0	5.5	2.0	15.0	34.0	19.0
B1VH - 3M	2.4	0,093	0.2	3mm Hy-Lok	50.8	25.4	25.4	9.5	8.8	28.0	5.5	2.0	15.0	34.0	19.0
B1VH - 2T			0.2	1/8 Hy-Lok											
B1VF - 2N	3.2	0,125	0.5	1/8 Female NPT	41.2	20.6	20.6	9.5	8.8	28.0	5.5	2.0	15.0	34.0	19.0
B1VH - 6M			0.6	6mm Hy-Lok											
B1VH - 4T			0.6	1/4 Hy-Lok											
B2VF - 2N			1.2	1/8 Female NPT											
B2VF - 4N	4.8	0,187	0.9	1/4 Female NPT	52.4	26.2	26.2	9.5	8.8	28.0	5.5	2.0	15.0	34.0	19.0
B2VF - 4R			0.9	1/4 ISO Female Tapered											
B2VM - 4N			1.2	1/4 Male NPT											
B2VMH - 4N4T			1.6	1/4 Male NPT   1/4 Hy-Lok											
B2VH - 6M			2.4	6mm Hy-Lok											
B2VH - 4T			2.4	1/4 Hy-Lok											
B2VH - 8M	1.5	8mm Hy-Lok	62.0	31.0	31.0	11.3	10.0	39.0	6.0	2.5	20.0	41.2	21.0		
B2VH - 6T	1.5	3/8 Hy-Lok	65.0	32.5	32.5										
B3VF - 4N	7.1	0,281	3.0	1/4 Female NPT	63.6	31.8	31.8	17.5	14.3	51.0	9.0	3.0	28.0	52.8	33.0
B3VF - 6N			2.6	3/8 Female NPT											
B3VF - 6R			2.6	3/8 ISO Female Tapered											
B3VH - 6T			6.0	3/8 Hy-Lok											
B3VH - 10M			6.0	10mm Hy-Lok											
B4VF - 8N	10.3	0,406	6.3	1/2 Female NPT	79.2	39.6	39.6	22.0	17.5	77.0	10.0	3.0	39.0	67.0	41.0
B4VF - 8R			6.3	1/2 ISO Female Tapered											
B4VH - 12M			12.0	12mm Hy-Lok											
B4VH - 8T			12.0	1/2 Hy-Lok											
B4VH - 12T	6.4	3/4 Hy-Lok	100.0	50.0	50.0										

All dimensions are in millimeters. Dimensions shown with Hy-Lok nuts in finger-tight position, where applicable

### Flow Rate

Pressure Drop to Atmosphere ( $\Delta p$ ) in psi		Cv														
		0.1	0.2	0.5	0.6	0.9	1.2	1.5	1.6	2.4	2.6	3.0	6.0	6.3	6.4	12.0
Air SCFM @70°F(21°C)	10	1.1	2.7	6.9	8.3	12.0	17.0	21.0	22.0	33.0	36.0	41.5	83.0	87.2	88.6	166.0
	50	3.0	7.6	19.1	23.0	34.0	46.0	57.0	61.0	92.0	99.5	115.0	230.0	241.0	245.0	459.0
	100	5.3	14.0	33.9	40.7	61.0	81.0	100.0	110.0	160.0	176.0	203.0	407.0	427.0	434.0	814.0
Water US GPM @70°F(21°C)	10	0.3	0.6	1.6	1.9	2.8	3.7	4.7	5.0	7.5	8.2	9.5	19.0	19.9	20.2	37.9
	50	0.7	1.4	3.5	4.2	6.3	8.4	11.0	11.0	17.0	18.4	21.2	42.3	44.5	45.3	84.9
	100	1.0	2.0	5.0	6.0	9.0	12.0	15.0	16.0	24.0	26.0	30.0	60.0	63.0	64.0	120.0

The Cv is for the straight pattern valves. Cvs of angle pattern valves are the same as those of 3-way valves

### 3 - way (Switching Valves)

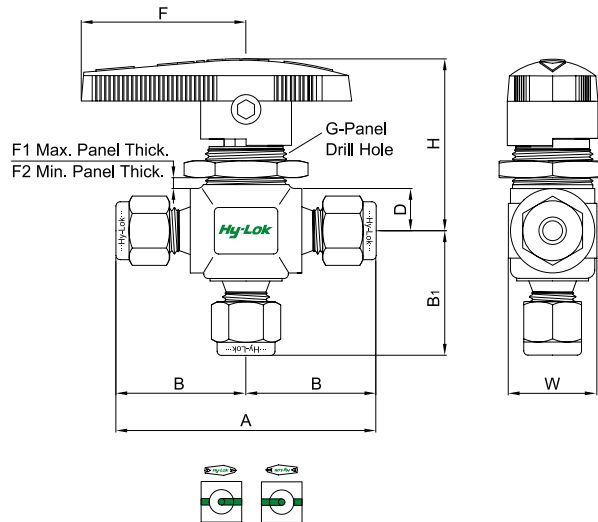

Table of Dimensions

Basic Part No.	Orifice		Cv	End Connection		Dimensions (mm)									
	mm	inch		Side port	Bottom port	A	B	B1	D	F	F1	F2	G	H	W
B1V3H -1T	1.3	0.052	0.08	1/16 Hy-Lok		42.6	21.3	20.6	8.8	28.0	5.5	2.0	15.0	34.0	19.0
B1V3H -3M	2.4	0.093	0.15	3mm Hy-Lok		50.8	25.4	24.6	8.8	28.0	5.5	2.0	15.0	34.0	19.0
B1V3H -2T			1/8 Hy-Lok												
B1V3F -2N	3.2	0.125	0.30	1/8 Female NPT		41.2	20.6	20.6	8.8	28.0	5.5	2.0	15.0	34.0	19.0
B1V3H -6M			6mm Hy-Lok												
B1V3H -4T			1/4 Hy-Lok												
B2V3F -4N			1/4 Female NPT												
B2V3F -4R	4.8	0.187	0.75	1/4 ISO Female Tapered		52.4	26.2	26.2	10.0	39.0	6.0	2.5	20.0	41.2	21.0
B2V3H -6M			6mm Hy-Lok												
B2V3H -4T			1/4 Hy-Lok												
B2V3HM -4T4N			1/4 Hy-Lok	1/4 Male NPT	60.4	30.2	29.5								
B2V3H -8M			8mm Hy-Lok		62.0	31.0	30.2								
B3V3F -4N	7.1	0.281	1.7	1/4 Female NPT		63.6	31.8	31.8	14.5	51.0	9.0	3.0	28.0	52.8	30.0
B3V3F -6N			3/8 Female NPT												
B3V3F -6R			3/8 ISO Female Tapered												
B3V3H -6T			3/8 Hy-Lok		73.2	36.6	35.8								
B3V3H -10M			10mm Hy-Lok												
B4V3F -8N	10.3	0.406	3.5	1/2 Female NPT		79.2	39.6	39.6	17.5	77.0	10.0	3.0	39.0	67.0	41.0
B4V3F -8R			1/2 ISO Female Tapered												
B4V3H -12M			12mm Hy-Lok												
B4V3H -8T			1/2 Hy-Lok		89.0	44.5	44.5								
B4V3H -8T			1/2 Hy-Lok												
B4V3H -12T			3/4 Hy-Lok												

All dimensions are in millimeters. Dimensions shown with Hy-Lok nuts in finger-tight position, where applicable

### Flow Rate

Pressure Drop to Atmosphere ( $\Delta p$ ) in psi		Cv												
		0.08	0.15	0.30	0.35	0.75	0.8	0.9	1.5	1.7	2.0	3.5	3.8	4.6
Air SCFM @70°F(21°C)	10	0.9	2.0	4.2	4.8	10.0	11.0	12.0	20.8	23.5	27.7	48.4	52.6	63.7
	50	2.4	5.7	11.5	13.4	29.0	31.0	34.0	57.4	65.0	76.5	134.0	145.0	176.0
	100	4.3	10.1	20.3	23.7	51.0	54.0	61.0	102.0	115.0	136.0	237.0	258.0	312.0
Water US GPM @70°F (21°C)	10	0.3	0.4	0.9	1.1	2.3	2.5	2.8	4.7	5.4	6.3	11.1	12.0	14.5
	50	0.6	1.0	2.1	2.5	5.3	5.6	6.3	10.6	12.0	14.1	24.7	26.9	32.5
	100	0.8	1.5	3.0	3.5	7.5	8.0	9.0	15.0	17.0	20.0	35.0	38.0	46.0

## Testing

- Each valve is tested with nitrogen @ 1000psig(69bar) to max leak rate of 0.1SCCM.
- Optional tests are available upon request.

## Sour Gas Service

- is provided to meet NACE Standard MR - 01 - 75.

## Packing Adjustment

- Valves are factory adjusted for 1000psig service at 70°F(21°C).
- For services at higher pressure, the packing must be readjusted. This can be done with the valve in - line. Untighten the hex key to remove the handle. Tighten the packing bolt clockwise with the increment of **a quarter of a quarter** turn (22.5°) until leaktight seal is obtained. And then reassemble.
- Exposure of valves to varying temperature can affect the initial packing load. You may need check leak and readjust packing bolt.

## Ordering Information

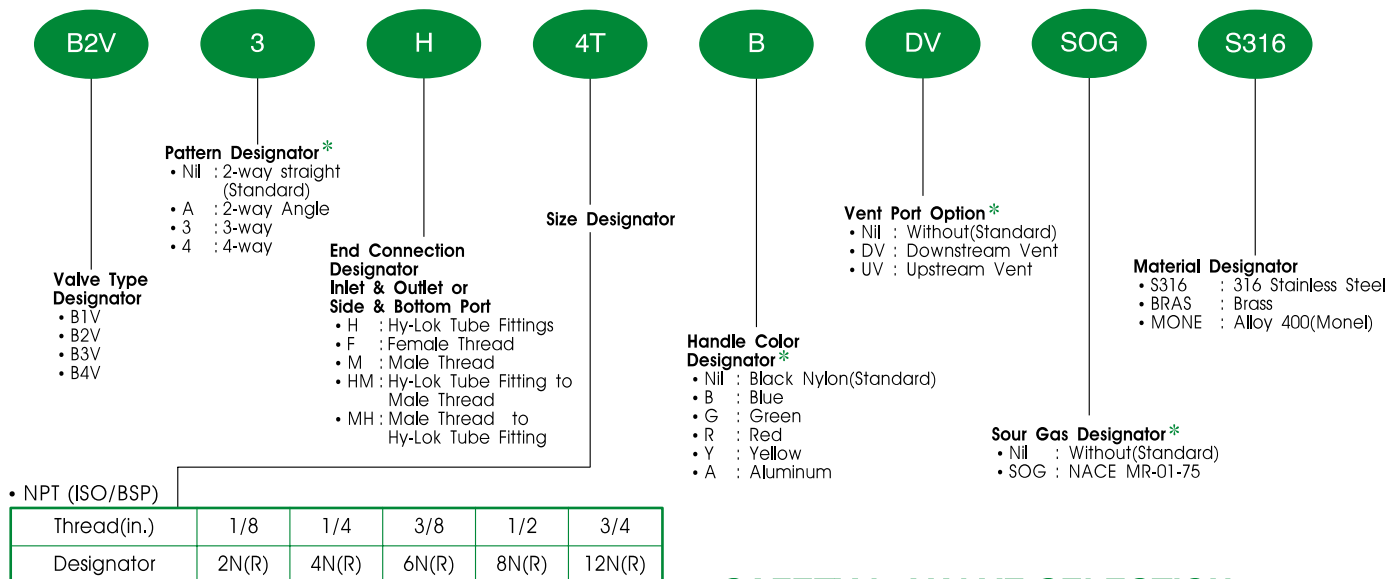

• Tube

Fractional Tube	O.D(in.)	1/16	1/8	1/4	3/8	1/2	5/8	3/4
	Designator	1T	2T	4T	6T	8T	10T	12T
Metric Tube	O.D(mm)	3	6	8	10	12	16	20
	Designator	3M	6M	8M	10M	12M	16M	20M

**Note\* :** No designator is required for standard, black nylon handle, e.g.B2VH-4T-S316.

## SAFETY in VALVE SELECTION

Proper installation, materials compatibility, operation and maintenance of these valves are the responsibility of the user. The total system design must be taken into consideration to ensure optimal performance and safety.

### ■ QUALITY SYSTEM CERTIFICATES



ISO 9001  
CERTIFICATE NO. GQC 212

ASME SECT III (MO)  
CERTIFICATE NO. QSC 584

### ■ TYPE APPROVALS (For Hy-Lok Tube Fittings)



American Bureau Shipping  
CERTIFICATE NO.00-BK50288-X



Lloyd's Register  
CERTIFICATE NO.01/10075



GERMANISCHER LLOYD  
CERTIFICATE NO.57798 - 91 HH



DET NORSKE VERITAS  
CERTIFICATE NO.P - 9100



Distributed by :

www.hy-lok.com